



**Pioneer Industrial Doors**  
P.O. Box 338  
Spring Hill, TN 37174  
Ph: 1.866.753.2655 • Fax: 931.486.0316  
[www.pioneerindustrialdoor.com](http://www.pioneerindustrialdoor.com)

## **Vinyl Door “Under Header” Mounting Requirements**

*The following document covers the mounting requirements and general configuration for a Pioneer “under Header” Vinyl Door. These are the general requirements for a typical installation. If your configuration requires a unique or custom mount design please do not hesitate to contact the factory for engineering assistance.*

### **Mounting Overview:**

The Pioneer’s “Under Header” Vinyl Door is installed completely within the jamb of the door opening and therefore reduces the effective opening size of your door. On each side of the opening the Pioneer’s Custom Aluminum Vertical Extrusions project inward by 2.5”. The flexible EPDM (rubber) edge seals project inward by an additional 1.5”. Therefore the overall reduction in effective door opening width is 8” (4” per side).

The top portion of the Pioneer’s Vinyl Door consists of custom mounting bracketry, a 3” aluminum roll tube and a “Double Baffle” and support bar. These components mount directly under the header of the opening and project downward into the opening by 9”, reducing the “headroom” by that amount.

The diagram on the following page (Diagram #1) shows the general layout and opening reduction dimensions for this mounting style.

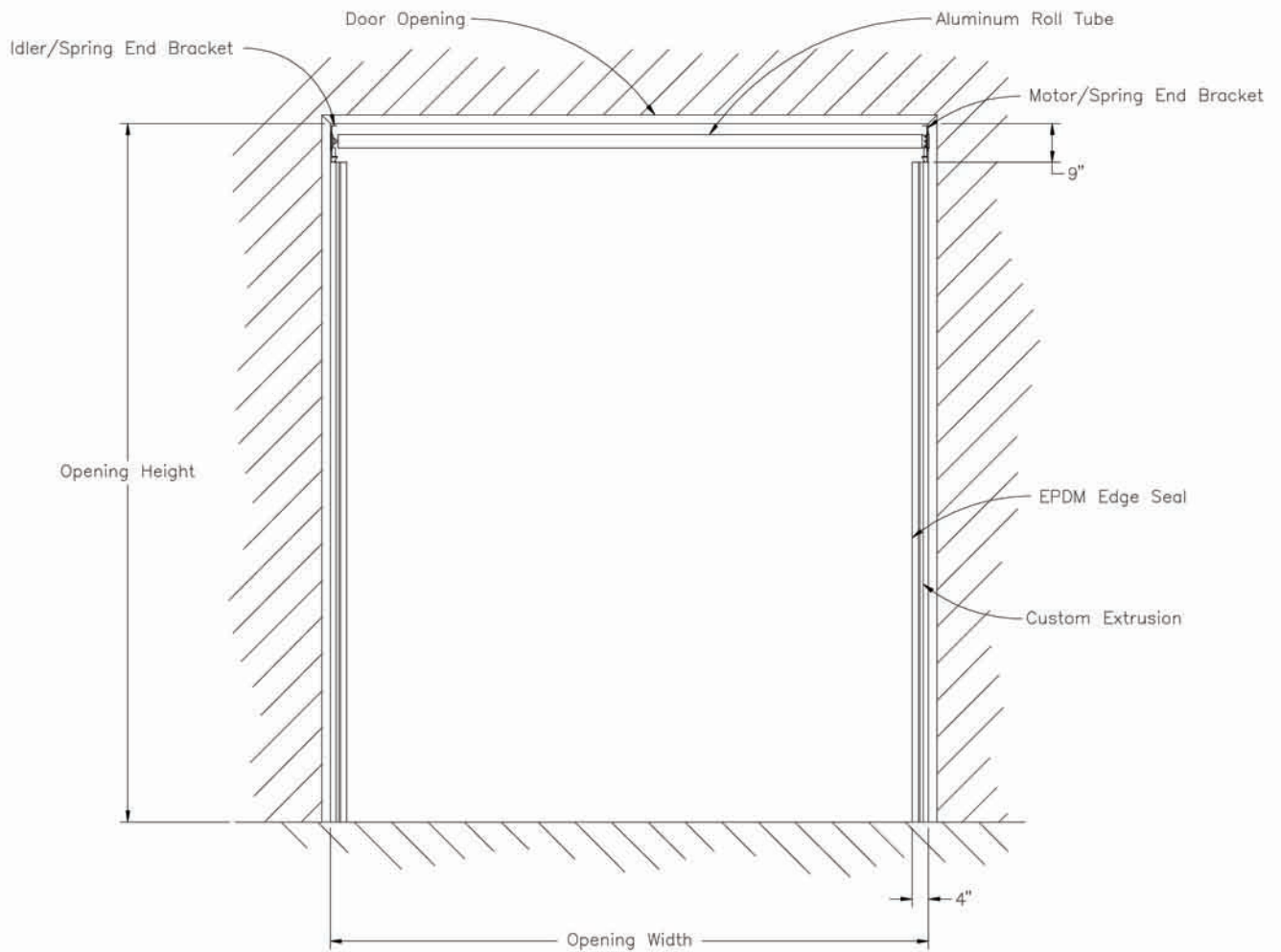

**Diagram #1  
(General Layout)**

**Jamb Preparation:**

The Under Header Door requires a smooth, flat, and uniform door jamb with at least 8" of width (wall thickness). All of the door hardware with the exception of the valence panel will mount directly to the side jambs. See the following diagram (Diagram #2).

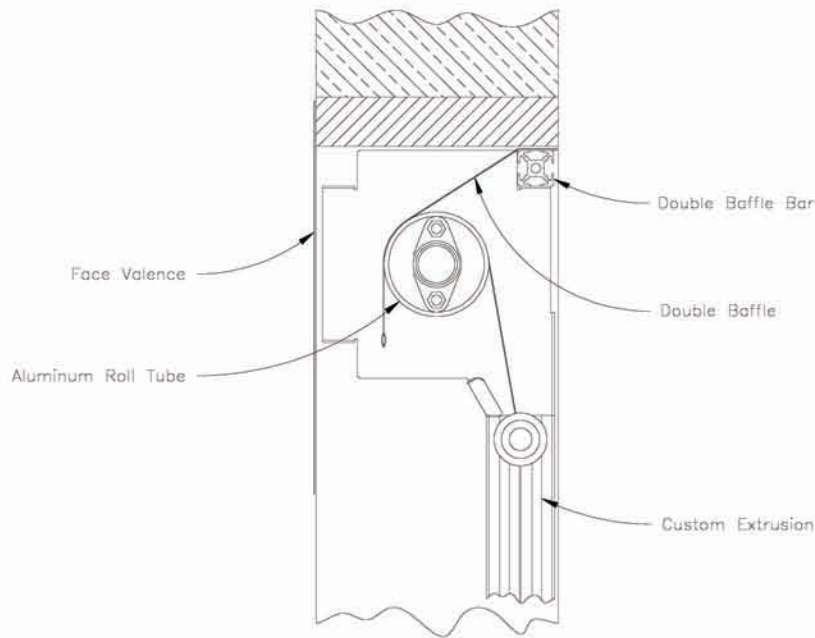

**Diagram #2  
(Jamb Layout)**

**Valence Installation:**

The Face Valence is sized 6” wider than the stated door opening and has a fixed height of 18”. It is designed to be mounted to the external (exterior) “fascia” of the building with 3” of overlap on each side. The valence is mounted so that the bottom edge of the panel is approximately even with the bottom edge of the vinyl door when the door is in the fully open position. The creation of a flat and uniform mounting surface for the valence panel may be required. Please see the following picture (Picture #1) for a representation of an installed Face Valence.



**Picture #1  
(Face Valence)**

### **Narrow Jamb Installation:**

On some installations (header depth less than 8”) the Motor/Spring and Idler bracketry will extend past the exterior fascia of the building as shown in the following diagram (Diagram #3). This is typically not a problem and the “bulge” will be covered with the front valence panel. If the protrusion is excessive a valence panel stand-off or custom valence panel may have to be fabricated. Do not attempt to mount the “Under Header” Vinyl Door when the jamb/header depth is less than 6”. Please contact the factory if you need assistance.

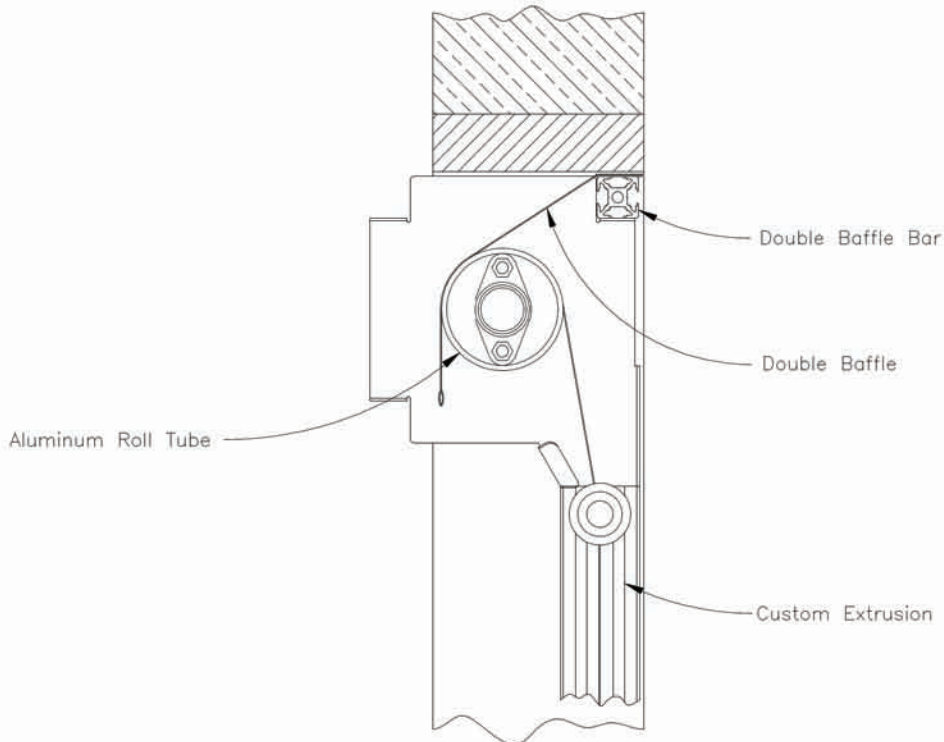

**Diagram #3  
(Narrow Jamb Layout)**

### **Door Sizing:**

**While the Pioneer Vinyl Door can accommodate minor variances and errors in the stated door size, the best performance and sealing will be achieved by giving accurate dimensions to the factory. Whenever possible, measure the door opening to the nearest .5” (one half inch). Modifying the vinyl door in the field to compensate for door opening size errors is typically not possible.**