



Pioneer Industrial Doors  
PO Box 338 • Spring Hill, TN 37174  
Toll Free: 866.753.2655  
Fax: 931.486.0316  
[www.pioneerindustrialdoor.com](http://www.pioneerindustrialdoor.com)

## Installation Instructions RollRight 302 Vertical Vinyl Curtain Door “Face Mount with External Operator”

*We have pre-assembled the roller, valence, and bracketry components for your Motorized Door. This should dramatically simplify the installation procedure. While the installation is very straightforward, please note the following details.*

### **System Overview:**

Your Pioneer Vinyl Vertical Curtain Door is a high quality, high performance flexible door system based on proven components and our many years of experience in the vinyl partition fabrication business. We are confident that it will bring you and/or your customers' years of reliable and trouble-free service.

Your specific system is a vinyl motorized roll-up curtain door with face-mount bracketry and an external operator. The “back-to-back” mounting dimension for your vertical extrusions will be the door opening width plus approximately 8” (eight inches). The vertical extrusions are cut to the same height as your stated door opening, which will place the entire motorized roll, upper bracketry, and valence box above the door header.

### **Unpacking and Inspection:**

Please unpack your systems carefully and notify the factory immediately if there are any shortages or if any items have been damaged during transit. Your kit(s) should have all of the necessary hardware and components for a complete installation with the following exceptions (installer-provided hardware):

1. Mounting hardware for securing the custom extrusions, bracketry and external operator to the building fascia.
2. Hardware and conduit associated with the professional electrical installation of the 115VAC source power.

## System Assembly:

### Site Preparation:

**It is imperative that the heavy duty bracketry for your door assembly is mounted to a flat and uniform surface. Mounting the door to an uneven surface can cause the bracketry to bend and distort, causing improper door operation and premature failure.**

**Sections of vinyl stripping are in place to stop the vinyl door from unrolling during installation. DO NOT remove these straps until after the drive chain has been installed!**

Lay the upper box section of your door on a flat surface and measure the “back-to-back” angle bracket dimension for your specific door as shown in the following photo (Photo 1). In this specific case the dimension is 106”.



**Photo #1**

(Angle Bracket Back-to-Back Dimension)

Divide this number by 2 (53” in this specific case). This will be your “A” dimension.

Lay one of your custom vertical extrusions (side rails) on a flat surface and measure the overall length of the extrusion as shown in the following photo (Photo 2). In this specific case the dimension is 143.75” (143 ¾”).



**Photo #2**

(Extrusion Overall Length Dimension)

Add .25" ( $\frac{1}{4}$ ") to this dimension (144" in this specific case). This will be your "B" dimension.

Make a mark on your building fascia "A" inches to the right from the top centerline of your door opening. This mark will correspond to the approximate edge location for your angle bracket. Repeat this process to the left of your opening centerline.

Make a horizontal line on your building fascia to the left and right of your opening at "B" inches from the ground surface. This line will correspond to the bottom edge of your angle brackets.

The angle brackets have a footprint of approximately 3" to each side of the "A" mark and 14" above the "B" line as shown in the following diagram (Diagram 1). Make sure that this area is smooth, flat, and even.

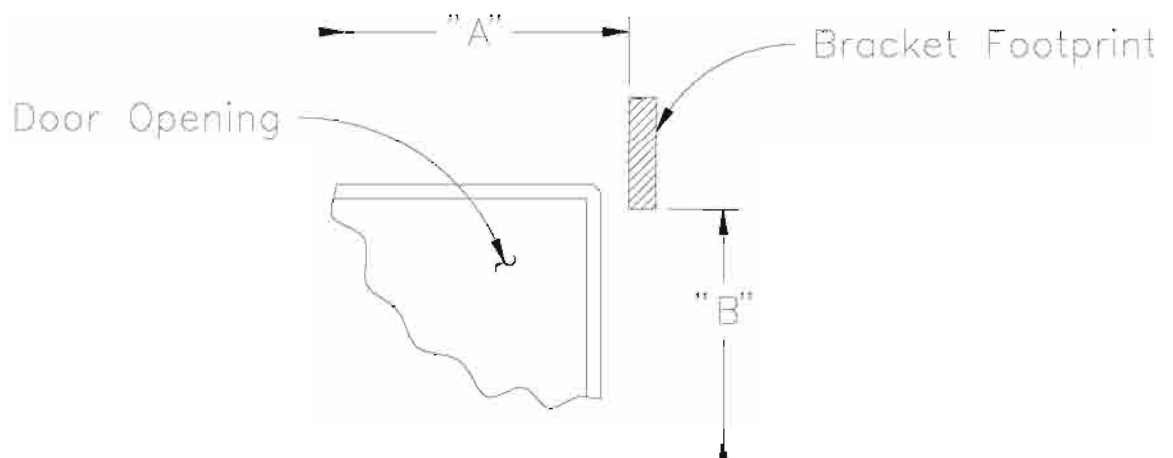

**Diagram #1**

(Angle Bracket Mounting Footprint)

### Upper Box Mounting:

The Upper Box Section of your door is best installed by two people with individual ladders, one person and a scissors lift, or some other mechanism for raising and holding the box in position while it is being secured to the building fascia. The box section should not be bent or distorted while it is being mounted.

Raise the box section to the elevation of your opening header and use the "A" marks to center it about your door opening. Carefully adjust the elevation of the box ends until the bottoms of the angle brackets are in alignment with the "B" lines. Secure the left bracket to your building fascia using one fastener and washer as shown in the following photo (Photo 3). The specific fastener type will be a function of your building material, but each fastener should be at least 1/4" in diameter and capable of handling at least 100lbs of shear and pull force.

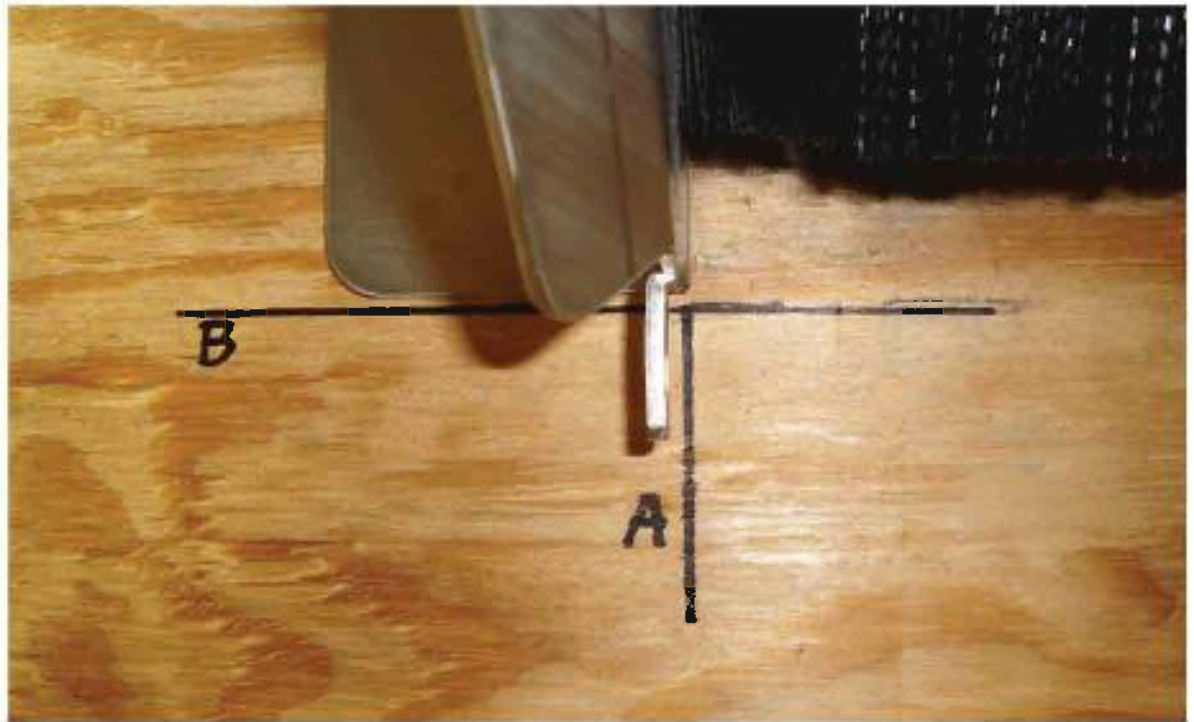

**Photo #3**

(Angle Bracket Alignment and Mounting)

Repeat this procedure on the right bracket. Double check the alignment of the door brackets and ensure that the box structure is not bent or distorted. Install the remaining four fasteners and washers in the angle brackets.

### Vertical Extrusion Mounting:

The Custom Vertical Extrusions will first be secured to the angle brackets on the upper box section, and then secured to the building fascia via "J" brackets.

It is suggested that the galvanized brackets first be mounted to the extrusions. Typically one bracket is mounted approximately flush to the bottom end of the vertical extrusion and one bracket is mounted at the mid point. This can be accomplished by laying the extrusion

and the bracket on a flat surface, transferring at least one bracket hole location to the extrusion, drilling a .28" diameter hole in the extrusion, and securing the bracket to the extrusion with a ¼-20 x .50 Pan Head Screw, ¼" Flat Washer, and a ¼-20 Hex Nut as shown in the following diagram (Diagram 2). Be very careful when drilling the Vertical Extrusions as to not damage the PVC seal strips and note the dimension for the proper location of the screw hole from the front "face" of the extrusion. There is a "drill start" groove inside of the extrusion which will help to locate the center line if you chose to drill the hole from the "inside" of the extrusion.

Alternately, for a "cleaner" installation or if there is insufficient door jamb for the standard mounting method, the "J bracket" can be flipped so that the mounting flange is "underneath" the extrusion (see Diagram 2). To do this, mount the Vertical Extrusion to the top bracketry per the instructions below, ensure the verticals are "plumb", mark the outside edge location of the vertical on the wall/jamb, remove the vertical, mount the J-bracket to the wall/jamb, reinstall the vertical and secure it to the J-bracket.

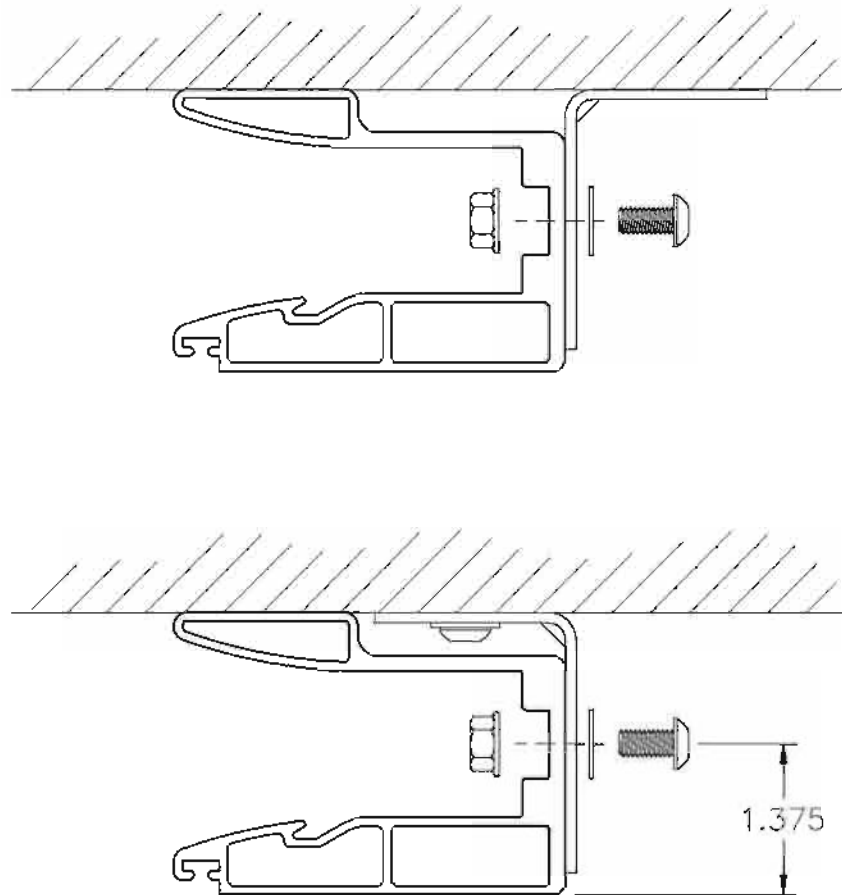

**Diagram #2**  
(J-Bracket Alignment and Mounting)

Locate the left vertical extrusion (marked with a "TL") and orient it so that the extrusion is on the left side of your opening with the "TL" at the top and facing out. Secure the vertical extrusion to the angle bracket using the supplied ¼-20 custom carriage bolt, nut and washer as shown in the following photo (Photo 4). Do not substitute any other fastener for the custom carriage bolt supplied.



**Photo #4**  
(Vertical Extrusion Orientation and Mounting)

Use a Carpenters' level or a Plumb Bob to ensure that the left extrusion is completely vertical. Secure the "J" brackets to the building fascia using "best practices" as a function of the building material. The mounting should resemble the following photo (Photo 5):



**Photo #5**  
("J" Bracket Mounting)

Orient the right vertical extrusion (marked with a "TR") so that it is on the right side of your opening with the "TR" at the top of the extrusion facing out. Secure the vertical extrusion to the angle bracket using the supplied 1/4-20 custom carriage bolt, nut and washer.

Use a tape measure to ensure that the left and right vertical extrusions are parallel ( $\pm 1/2$ "') and secure the right extrusion "J" brackets to the building fascia using "best practices" as a function of the building material.

## Safety Eye Installation:

Although it is an optional component, the reflective photo-eye is an important safety device and can help to avoid injury to personnel and damage to your motorized door system.

Select a suitable elevation for the installation of the photo-eye. Typically this is a few inches off of the floor level, but it can be installed at virtually any height.

Drill a 3/16" (.1875") hole at the desired elevation, one inch from the edge of the vertical extrusion opposite of the external operator. Only drill through the front wall of the extrusion. Secure a J-bracket to the front surface of the Vertical Extrusion using the supplied #14 x 1/2" sheet metal screw and washer as shown in the following diagram (Diagram 3):

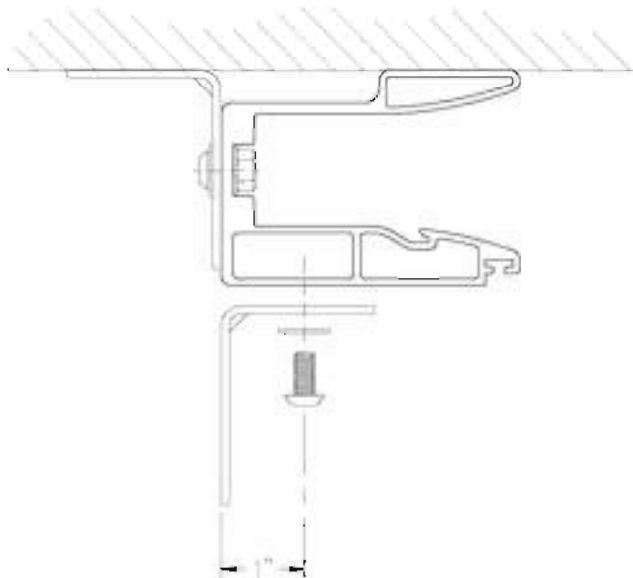

**Diagram #3**  
(Reflector J-bracket Mounting)

Attach the photo-eye reflector to the J-bracket using the supplied hardware. Your installation should resemble the following photo (Photo 6):



**Photo #6**  
(Reflector Mounting)

Per the following photo (Photo 7), attach the reflective head unit bracket to the opposite Vertical Extrusion. Set the height of the bracket to match the elevation of the reflector, transfer the slot locations to the Vertical Extrusion and drill two .28" diameter holes for the fasteners. Make sure the holes go through the center of the internal slot (1.375" from the front surface). Secure the bracket to the Vertical using the supplied ¼-20 x .50 Pan Head Screws, ¼" Flat Washers, and a ¼-20 Hex Nuts. Assemble the head unit and protective cover to the bracket using the supplied hardware. Make sure that the head unit is aligned with the reflector.

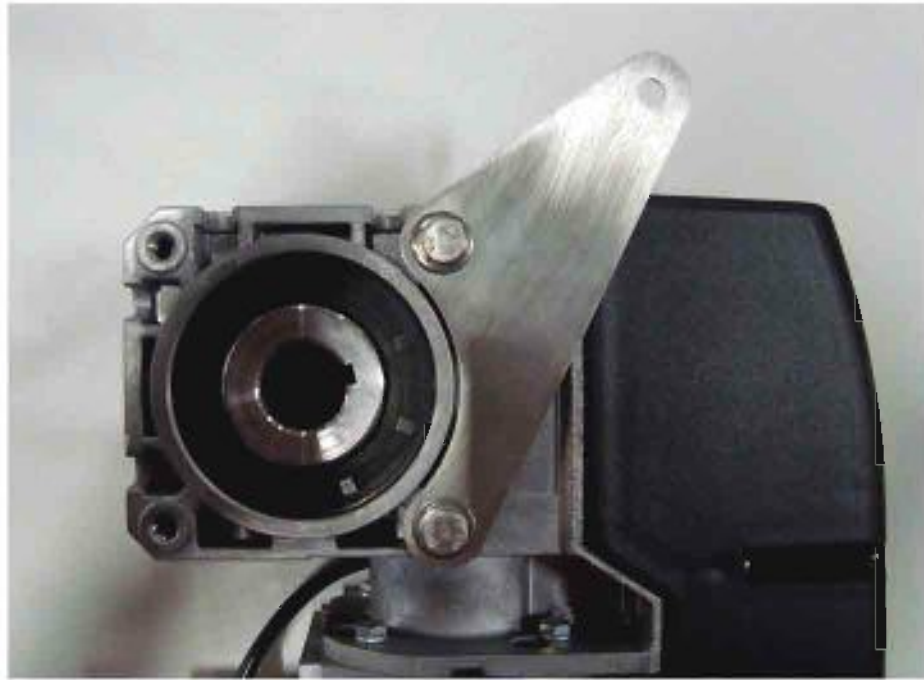

**Photo #7**  
(Head Unit Mounting)

#### HarshGuard Operator Preparation:

Carefully remove the HarshGuard External Operator from its shipping carton. Use care when handling the operator as to not damage the plastic housing or capacitor mount. Locate the Operator Adapter Bracket, two M8 metric bolts, two lock washers and two flat washers. Do not confuse the two M8 bolts with the single 5/16-18 bolt that is also in the kit. Install the Adapter Plate as shown in the following photo (Photo 8) (Right-hand operator shown, install the adapter on the opposite side of the operator for Left-hand installations):





**Photo #8**  
(Operator Adapter Plate)

**HarshGuard Operator Mounting:**

Install the Hand Crank in the bottom of the operator. Ensure that the crank goes all the way into the plastic housing and rotate the crank until it fully engages the motor drive shaft. Rotating the crank should cause the 1" output quill drive on the operator to turn.



**Photo #9**  
(Hand Crank)

Install the ¼” square key into the pocket slot in the Input Shaft, hold in place as required. Carefully lift the operator into place next to the Input Shaft. Using the hand crank, rotate the output quill until the keyway lines up with the key on the Input Shaft. Slide the operator all the way onto the Input Shaft. It may be necessary to rock the operator slightly in order to get it all the way onto the shaft. **Do not force the operator or use a hammer to get the unit onto the shaft!**

Rotate the operator until the hole in the Adapter Bracket is in alignment with the tapped hole in the upper box aluminum support. Secure the bracket to the support with the 5/16-18 bolt and flat washer as shown in the following photo (Photo 10):



**Photo #10**  
(Operator Fastener)

At this point it is now safe to cut and remove the vinyl safety straps. Carefully unroll the bottom of the door and guide the bottom door sweep (chain pocket) into the Vertical Extrusions on both sides of the door.

Use the hand crank to lower the door approximately one foot (1') from the “Open” position. Remove the operator cover (5 fasteners). The next step will involve pre-setting the approximate end stop (limit) positions for the operator travel. Locate the 2.5 Allen key included with your installation kit. Use it to loosen set screw for the first **GREEN** limit cam on the operator. Rotate the cam until the lobe of the cam comes in contact with the arm of the microswitch (from the under-side) and you can hear the switch click. Tighten the set screw firmly as shown in the following photo (Photo 11):

**NOTE:** If it is not possible to access the head of the set screw, use the hand crank to lower the door until the head is exposed. Loosen the screw, and then use the hand crank to raise the door back to the ~1' position. It is important that the door be approximately one foot from fully open when the starting position for the cam is set.



**Photo #11**  
(Open Cam Coarse Adjustment)

Loosen the set screw for the first WHITE limit cam on the operator. Rotate the cam until the lobe is at the “3 o-clock” position as shown in the following photo (Photo 12). Tighten the screw firmly.

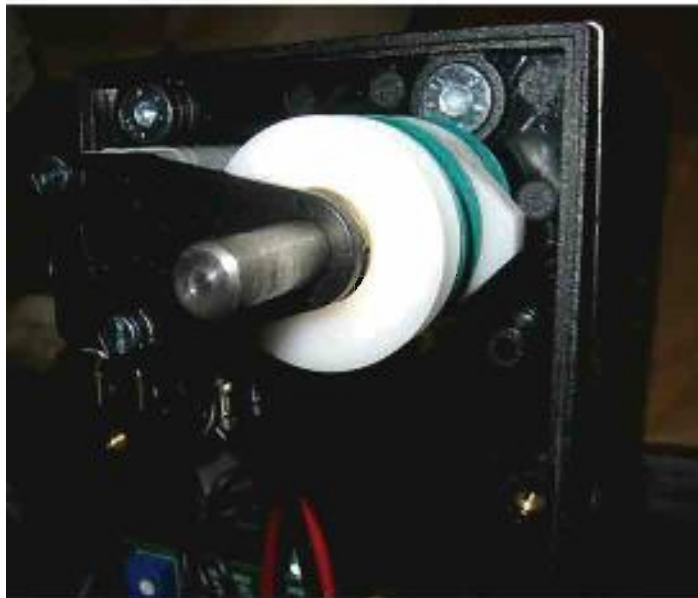

**Photo #12**  
(Close Cam Coarse Adjustment)

The other two outboard cams (white and green) are not electrically connected and are not used in a standard installation.

Using a small screwdriver, make sure that the “Auto-Close” potentiometer (P2) is rotated fully counter-clockwise as shown in the following photo (Photo 13). Failure to set this potentiometer properly will cause the door to automatically close during testing! Also make sure that the upper potentiometer (P1) is rotated fully counter-clockwise (factory position).



**Photo #13**  
(Auto-Close Potentiometer)

Locate the DIP Switch assembly and ensure that all of the switches are in the “OFF” (right) position as shown in the following photo (Photo 14):

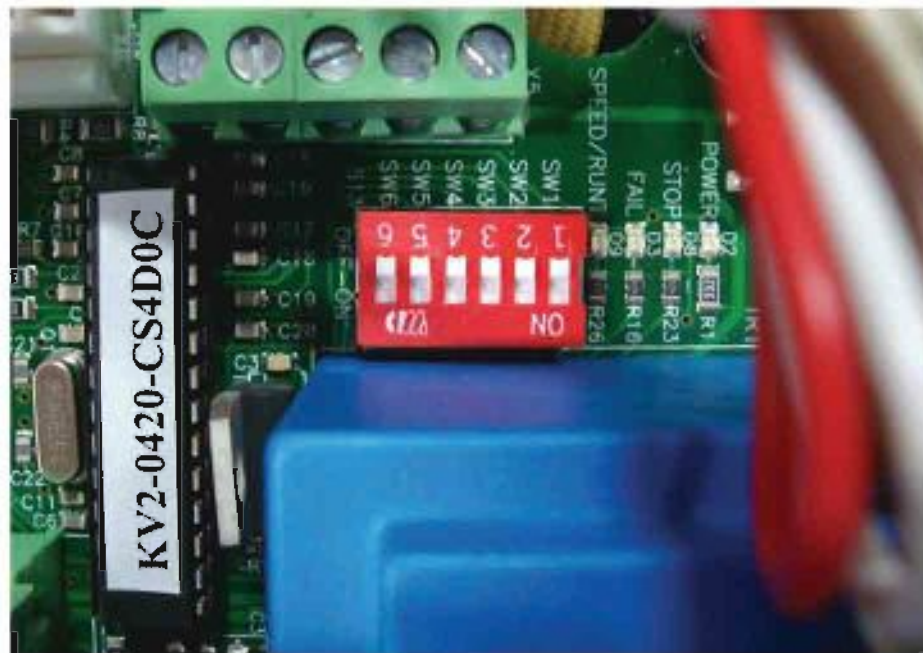

**Photo #14**  
(Initial DIP Switch Settings)

Locate the NEMA-4 3-button control station. Attach it to the NEMA mounting bracket using four 1/4-20 x .50 Pan Head Screws. Remove the top cover. Remove the lower plug in the enclosure and install one of the waterproof compression glands. Using a step drill or similar tool, remove the “knock-out” at the top of the box and install the remaining gland. Your assembly should resemble the following photo (Photo 15):



**Photo #15**  
(NEMA-4 Preparation)

Position the NEMA-4 box on the aluminum vertical under the operator (right or left side depending on the installation) approximately five feet (5') above the floor. Adjust the position to avoid interfering with the J-bracket as required. Using the bracket as a template, drill two .28" diameter holes in the vertical extrusion (Make sure the holes go through the center of the internal slot (1.375" from the front surface)) and secure the bracket to the extrusion with two ¼-20 x .50 Pan Head Screws, ¼" Flat Washers, and ¼-20 Hex Nuts as shown in the following photo (Photo 16):



**Photo #16**  
(NEMA-4 Mounting)

## Electrical Connections:

There are two independent and unique aspects of the wiring configuration for your Motorized Vertical Curtain Door. These are the 115VAC 60Hz power wiring and the low-voltage control wiring. While the low-voltage side of the control system can be configured and properly wired by anyone who has a rudimentary understanding of electrical circuitry, the power wiring should be performed by an electrical professional and done in such a manner to conform to all local and national wiring codes and regulations.

### 115VAC Power Wiring:

**The external operator requires 115VAC, 60Hz with a current draw of 5A (1/2 HP PSC inductive motor). Make sure that the branch circuit and conductor size can support this load requirement. Low voltage can cause erratic behavior and operator overheating. Do NOT enable the 115VAC power until all of the wiring has been completed.**

**Pro Tip: All of the green terminal connectors for the power and control wiring are actually “plugs”. They can be unplugged and removed to make for better access and ease of wiring.**

The AC power wiring should be brought into the operator via the right waterproof gland (or a suitable replacement fitting). Route the wiring up the side of the printed circuit board and connect the “Neutral” to the “N” terminal, “Hot” to the “L1” terminal, and “Ground” to the “PE” terminal. Note: Local electrical codes may not allow the Earth Ground to be attached to the terminal strip and bonding to the motor case may be required. The following photo (Photo 17) is for reference only and does not necessarily represent a “legal” wiring configuration.



**Photo #17**  
(115VAC Power Wiring)

Remove the inner gray seal from the lower waterproof gland and the NEMA-4 and route the free end of the cord for the Photo-Eye system through the gland. Feed the cord through until approximately six inches (6") of cord is inside of the box. Firmly tighten the gland and ensure that the cord is clamped.



**Photo #18**  
(Photo Eye Wire Routing)

#### Control Connections:

The operator supports NEMA-1 and NEMA-4 3-button control stations with N/O "Open" and "Close" buttons. The "Stop" buttons must be N/C. The low-voltage control connections for the primary (first) station should be made with the 8-conductor cable that was included with your kit. Although the color codes are arbitrary, Pioneer has selected the following standard:

- |          |   |              |
|----------|---|--------------|
| 1. Green | - | Common       |
| 2. Red   | - | Stop         |
| 3. Blue  | - | Open (UP)    |
| 4. White | - | Close (DOWN) |

Single-station control installations are performed by simply running the control wiring between the control station and the operator, and attaching the appropriate wires to the screw terminals on the operator and the control station.

Strip away the gray insulation from the 8-conductor cable and obtain a piece of green wire about 7 inches (7") in length. Use a short piece of this green wire and jumper between one of the N/O terminals on the Open button and one of the N/O terminals on the Close button. Make another jumper between the Close button terminal and the bottom N/C terminal on the Stop button. Your wiring should resemble the following photo (Photo 19):



**Photo #19**  
(NEMA-4 Common Wiring)

Take a free end of the 8-conductor cable and run it through the top waterproof gland on the NEMA-4 box, continue to feed the cable through the gland until approximately six inches (8") of cable is inside the box. Firmly tighten the gland and ensure that the cable is clamped. Your assembly should resemble the following photo (Photo 20):



**Photo #20**  
(NEMA-4)



Remove the gray insulation from the 8-conductor cable and cut, strip and terminate the control wiring as shown in the following photo (Photo 21). The green wire should be attached to any terminal that has a green jumper already attached to it. The blue wire is attached to the unused N/O terminal on the “Open” switch. The white wire is attached to the unused N/O terminal on the “Close” switch. The red wire is attached to the unused N/C terminal on the “Stop” switch.



**Photo #21**  
(NEMA 4 Control Wiring)

Strip the ends of the remaining 4 wires in the 8-conductor cable. Using the included wire nuts, attach these wires to the 4 wires coming from the Safety Edge per the following chart:

<u>8-Conductor Cable</u>		<u>Photo-Eye Cable</u>
Black	→	Brown
Brown	→	Black
Yellow	→	Blue
Orange	→	Orange

The White Photo-Eye wire is not used and may be clipped off. Make sure that the striped ends of the wires are twisted and that the wire nuts are properly installed. Your wiring should resemble the following photo (Photo 22):



**Photo #22**  
(Safety Edge Wire Nuts)

Carefully tuck the wiring and wire nuts under the switches. Dress the rest of the wiring so that the cover can be installed without pinching a conductor.



**Photo #23**  
(NEMA 4 Wire Dressing)

Install the cover on the NEMA 4 control box. Make sure that the cover is aligned properly and that the buttons operate freely.

Route the 8-conductor cable to the operator, through the waterproof gland on the left hand side, and firmly tighten the gland. Using a small screwdriver, remove the wire jumpers from the "Stop" and "Safety Device" terminals on the operator left hand terminal strip. Cut the cable to length, remove the gray insulation jacket, trim, strip, and terminal the wires as listed in the following chart:

<u>8-Conductor Cable</u>		<u>Operator Terminal</u>
Red	→	Bottom "Stop"
Green	→	Top "Stop"
White	→	"Close"
Blue	→	"Open"
Orange	→	Bottom "Safety Device"
Brown	→	Top "Safety Device"
Black	→	"-" (24VDC)
Yellow	→	"+" (24VDC)

Your wiring should resemble the following photo (Photo 24):

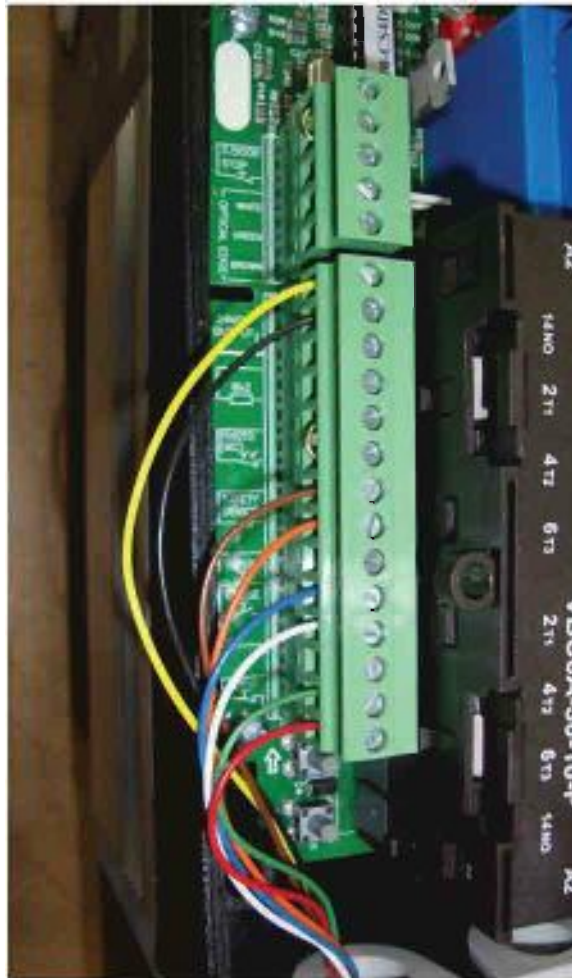

**Photo #24**  
(Operator Low Voltage Wiring)

## Preliminary Testing:

**Remove the hand crank.** The crank has an interlock switch and the door will not operate when the crank is inserted into the operator. Enable power (115VAC) to the unit. The door should not move and the green power LED should illuminate on the operator printed circuit board. If the door should begin to move, immediately disable the power and check/repair the control wiring from the NEMA-4 station to the operator.

Remove the protective rubber cap from the photo-eye head unit, and open the clear plastic door. Set the slide switch to “Dark Operation “ (DK) by sliding it to the “left”.

Observe the LEDs on the photo-eye head unit. The RED and YELLOW LEDs should be illuminated. When the cross-beam is broken (blocked) the RED LED should go out and the GREEN LED should illuminate. Adjust the mechanical alignment of the head unit and the sensitivity of the circuit to ensure reliable and robust operation. Close the clear plastic door and re-install the protective rubber cap.



**Photo #25**  
(Photo-eye settings)

There are two gray manual override buttons on the lower left edge of the operator printed circuit board as shown in the following photo (Photo 26). With all of the DIP switches in the “OFF” position, these buttons will operate in a “momentary” fashion, meaning that the door should move as long as the button is being held and it should stop when the button is released. Press the “Down” (lower) button and observe the action of the door. It should begin to close. Watch for mechanical binds and/or problems and release the button after the door has moved approximately a foot. Press the “Up” (upper) button and observe the action of the door. The door should move upward and stop when you release the button or when the “Open” limit switch (white cam) is tripped. Do not allow the bottom of the vinyl sweep (chain pocket) to rise above the tops of the aluminum Vertical Extrusions. If the door does not operate in the described manner please contact Pioneer for debug and technical support.



**Photo #26**  
(Manual Override Buttons)

#### Setting the End Limits:

The gross/coarse adjustment of the end limit cams is made by loosening the set screw for the cam and changing its position on the shaft. Fine tuning and small adjustments can be made by using the internal cam “phase screw” which can be accessed by putting the 2.5mm Allen wrench into the slot/hole of the cam as shown in the following photo (Photo 27):



**Photo #27**  
(Cam Phase Screw Adjustment)

If you run out of available travel on the “phase screw” it will be necessary to reposition the cam with the set screw and start over.

**NOTE: Always release the gray manual override buttons before adjusting the end position cams!**

Setting the limits is a two-step operation and either end stop can be modified at any time without upsetting the other position. It is preferred to initially have the door “stop short” of the desired position and then incrementally work toward the final adjustment. To set the “Full Down” (Closed) position press the gray “Close” button on the operator and monitor the position of the door.

The door should stop automatically before the bottom of the door contacts the floor. If it doesn't, release the “Close” button as the weighted bottom seal of the door contacts the floor and begins to compress. Press the “Open” button. Monitor the position of the door and release button when the door is open by approximately 1' (one foot). Using the Allen wrench, turn the phase screw on the white cam clockwise (CW) until the cam contacts the lever on the microswitch (from the top) and you can hear the “click”. Press the Open button and allow the door to open about an additional foot (1'). Press the “Close” button. The door should stop before the bottom of the door comes within three inches (3”) of the floor. You are now ready to incrementally work toward the final position.

Note the position of the door. Each full counter-clockwise (CCW) rotation of the phase screw will move the Closed stop position down by approximately 2”. Remove the appropriate number of turns (CCW) to the phase screw and press the “Close” button. Monitor the position of the door. It should automatically stop when the weighted bottom seal of the door is in full contact with the floor across the entire width of the opening. If the door does not reach this point, release the “Close” button and remove some more turns (CCW) from the phase screw. If the door closes too far, use the “Open” button to open the door a few inches, add some turns (CW) to the adjuster, and repeat the adjustment procedure.

Once the Closed position has been established, press the “Open” button on the operator in order to set the “full Up” position.

The door should stop automatically well before the bottom of the chain pocket reaches the top of the Vertical Extrusion. If it doesn't, release the “Open” button when the bottom of the door rollers are within ~2” of the top of the vertical extruded channels. **DO NOT** allow the curtain door to continue above this point. If it should happen to disengage the custom extruded tracks and completely wrap around the motorized roll it will become necessary to manually reset the rollers into the track and reestablish the “Closed” position via the above procedure. Press the “Close” button. Monitor the position of the door and release the button when the door is closed by approximately 1' (one foot). Turn the phase screw on the green cam counter-clockwise (CCW) until the cam contacts the lever on the microswitch (from the bottom) and you can hear the “click”. Press the “Close” button and allow the door to close about an additional foot (1'). Press the “Open” button. The door should now stop automatically before the bottom of the door reaches the top of the vertical extrusions. You are now ready to incrementally work toward the final position.

Note the position of the door. Each full clockwise (CW) rotation of the adjuster will move the Open stop position up by approximately 2”. Add the appropriate number of turns (CW) to the phase screw and press the “Open” button. Monitor the position of the door. It should automatically stop when the bottom set of rollers reach the top of the vertical

extrusions. If the door is not fully open, release the button and add some more turns to the adjuster. If the door opens too far, use the “Close” button to close the door a few inches, remove some turns (CCW) from the phase screw, and repeat the adjustment procedure.

Note the position of the door. Each full clockwise (CW) rotation of the adjuster will move the Open stop position up by approximately 2”. Add the appropriate number of turns (CW) to the phase screw and press the “Open” button. Monitor the position of the door. If the door is not fully open, release the button and add some more turns to the adjuster. If the door opens too far, use the “Close” button to close the door a few inches, remove some turns (CCW) from the phase screw, and repeat the adjustment procedure. The Open position should be set so that the bottom of the door “chain pocket” is flush with the bottom of the brush seal as shown in the following photo (Photo 28).. **DO NOT** set the upper stop position more than 2” above this point. Setting the Open position below this point will not hamper the function of the door, but the “auto reset” feature may not work reliably. Setting the Open position more than 2” above flush may cause reliability problems.



**Photo #28**  
(Open Position)

### **Final Setup and Operation:**

#### Conversion to “Maintained” Switching:

With all of the DIP switches in the “OFF” position the Open and Close buttons operate in a “momentary” manner. The door will move as long as the button is being pushed and the end limits have not been reached (or the Safety Edge has been tripped during a “Close” cycle). “Maintained” switching allows a user to push and release a button in order to initiate movement. After the button is pushed the door will continue to move until a different button is pushed, the Stop button is pressed, or the end limits are reached. In

order to convert the operator to “Maintained” mode, turn the SW1 and SW2 DIP switches “ON” (down) as shown in the following photo (Photo 29):

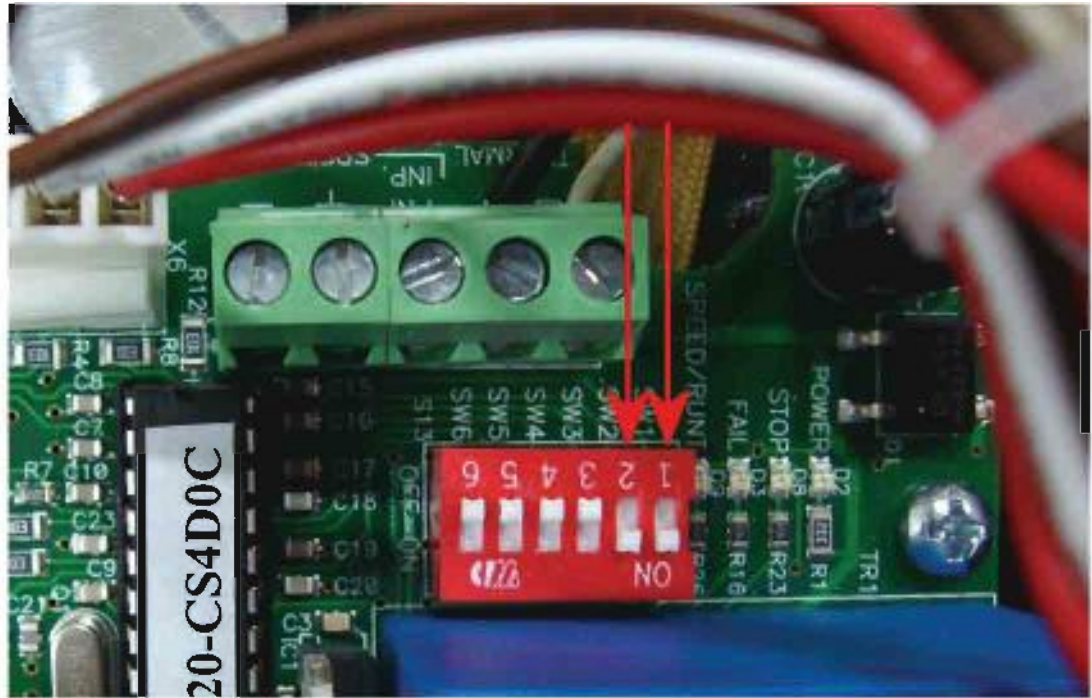

**Photo #29**  
("Maintained" Switches)

#### Final Assembly:

The mechanical and electrical setup of your door is now complete and you can install the cover on the operator.

**Note:** After repeated operation it is not unusual for the door material to continue to slightly “relax” and for the operator brake mechanism to “break-in” and have slightly different characteristics. It is wise to check the Open and Closed door positions settings after approximately 50 cycles and readjust as required.

The assembly, installation, and set-up of your Pioneer Motorized Curtain Door is now complete and it is ready for typical operation. It is a virtually maintenance free unit and should give you years of reliable service.

We want to thank you again for your business and the opportunity to partner with your firm on this project. Please don't hesitate to contact us if you have any questions regarding these instructions or encounter any problems with the installation or performance of your door.



# Addendum

## Adding Wired Control Stations:

Additional hard-wired control stations can be added to your external operator system. There is no limit to the number of stations that can be attached to the unit. The first (primary) control station is wired to the operator with 4-conductor wire while all subsequent stations require 5-conductor connections.

The "Open" and "Close" buttons on your control stations are N/O (Normally Open) and must be wired in PARALLEL. The "Stop" buttons are N/C (Normally Closed) and must be wired in SERIES (daisy chain).

### NEMA-4:

Although the color codes are arbitrary, Pioneer has selected the following standard:

1	Green	-	Common
2	Red	-	Stop
3	Yellow	-	Stop Return
4	Blue	-	Open (UP)
5	White	-	Close (DOWN)

Remove the cover of the NEMA-4 station and note the location of the N/O and N/C terminals for each button. The N/O terminals are located closer to the base and are on the "right" side of the station. The N/C terminals are raised and are on the "left" side.

Use a short piece of green wire from the 5-conductor "Thermo Wire" and jumper between one of the N/O terminals on the Open button and one of the N/O terminals on the Close button. Also connect the free end of the green wire in the 5-conductor bundle to one of these terminals.

Connect the rest of the wires as shown in the following photo (Photo 30). Note that the yellow and red wires go to the N/C terminals on the Stop button.

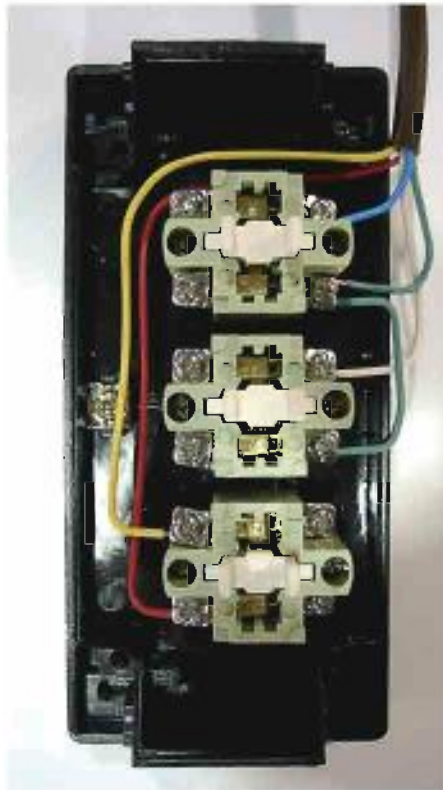

**Photo #30**  
(NEMA-4 Station Wiring)

Route the cable through one of the station knockouts and carefully reinstall the cover. Make sure that the cover is installed properly and that the buttons work freely.

#### Locking NEMA-4:

Although the color codes are arbitrary, Pioneer has selected the following standard:

6	Green	-	Common
7	Red	-	Stop
8	Yellow	-	Stop Return
9	Blue	-	Open (UP)
10	White	-	Close (DOWN)

Remove the cover of the Locking NEMA-4 station and note the location of the N/O and N/C terminals for each button. The N/O terminals are located closer to the base and are on the “right” side of the station. The N/C terminals are raised and are on the “left” side.

Use a short piece of green wire from the 5-conductor “Thermo Wire” and jumper between one of the N/O terminals on the Open button and one of the N/O terminals on the Close button. Make another jumper between the Close button terminal and the top N/O terminal on the Lock. Connect the free end of the green wire in the 5-conductor bundle to the bottom N/O terminal on the Lock.

Connect the rest of the wires as shown in the following photo (Photo 31). Note that the yellow and red wires go to the N/C terminals on the Stop button.

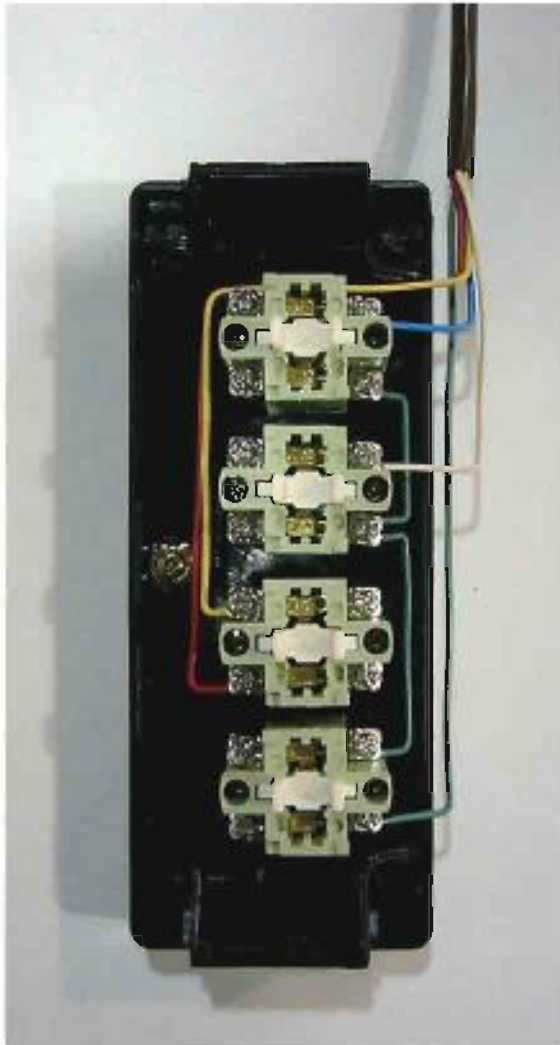

**Photo #31**  
(Locking NEMA-4 Station Wiring)

Route the cable through one of the station knockouts and carefully reinstall the cover. Make sure that the cover is installed properly and that the buttons work freely.

#### NEMA-1:

Although the color codes are arbitrary, Pioneer has selected the following standard:

11	Green	-	Common
12	Red	-	Stop
13	Yellow	-	Stop Return
14	Blue	-	Open (UP)
15	White	-	Close (DOWN)

Remove the cover of the NEMA-1 station and cut the bonding strip between the Close and Stop button terminals. See the following photo (Photo 32):

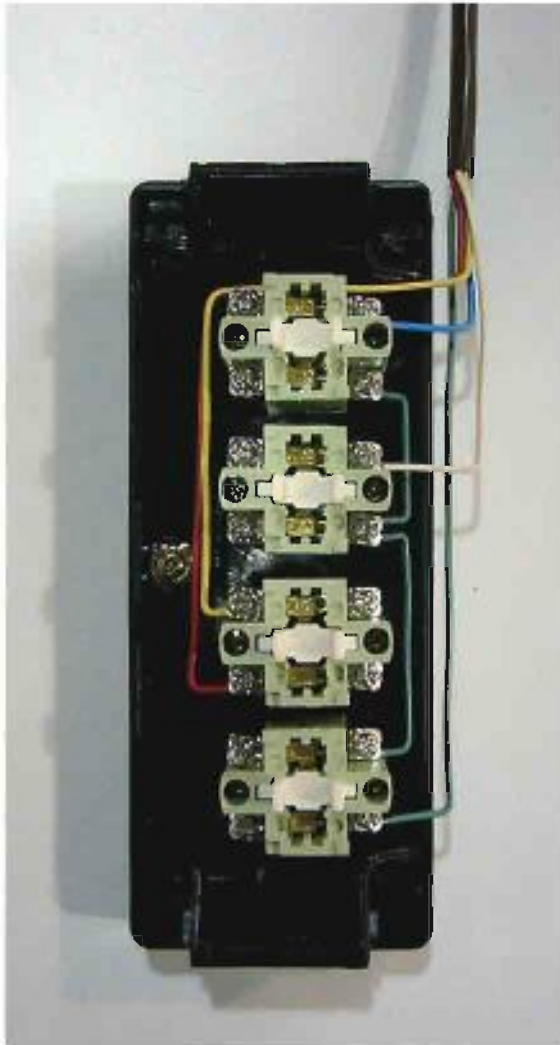

**Photo #31**  
(Locking NEMA-4 Station Wiring)

Route the cable through one of the station knockouts and carefully reinstall the cover. Make sure that the cover is installed properly and that the buttons work freely.

#### NEMA-1:

Although the color codes are arbitrary, Pioneer has selected the following standard:

11	Green	-	Common
12	Red	-	Stop
13	Yellow	-	Stop Return
14	Blue	-	Open (UP)
15	White	-	Close (DOWN)

Remove the cover of the NEMA-1 station and cut the bonding strip between the Close and Stop button terminals. See the following photo (Photo 32):



**Photo #32**  
(NEMA-1 Station Cut Point)

Connect the wires as shown in the following photo (Photo 33). Note that the yellow and red wires go to the N/C terminals on the Stop button.



**Photo #33**  
(NEMA-1 Station Wiring)

Route the cable through one of the station knockouts and carefully reinstall the cover. Make sure that the cover is installed properly and that the buttons work freely.

The other end of the 5-conductor “Thermo-Wire” is attached to the control terminals at the external operator. The blue (Open) wire connects to the same terminal as the blue wire from the primary control station (Terminal #5). The white (Close) wire will connect to Terminal #4, and the green wire (Common) connects to Terminal #2.

In order to connect the Stop buttons in series, disconnect the red wire from the primary control station from the Stop terminal on the operator. Use the included blue wire nut to fasten it to the yellow wire of the station that you are adding (5-conductor bundle). Connect the red wire for the new station to Stop terminal on the operator. Your connections should resemble the following photo (Photo 34):

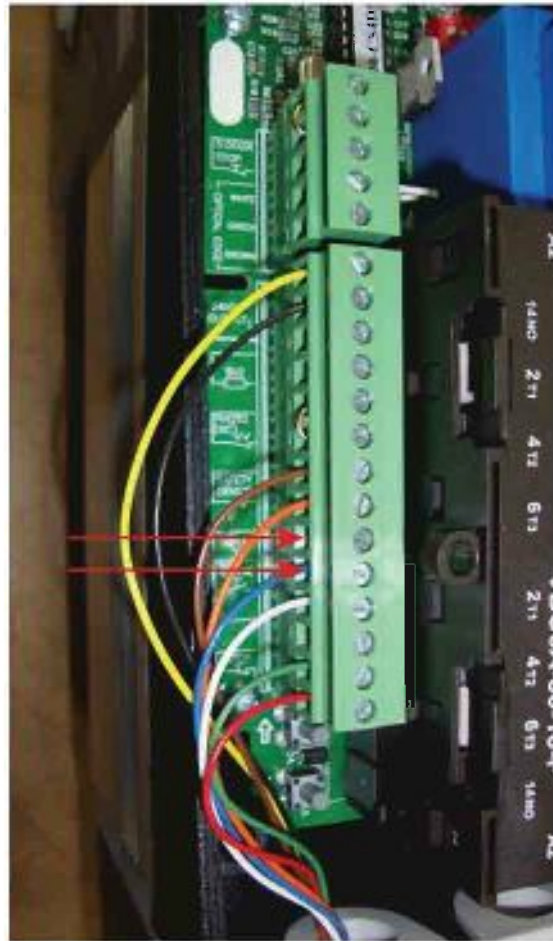

**Photo #34**  
(Additional Station Operator Wiring)

The wiring for the additional control station is now complete. You can continue to add control stations by following this same procedure. Connect the blue, white, and green wires to the corresponding terminals in the operator. Disconnect the red wire from the previous station from the Stop terminal, connect it to the yellow wire for the new station (wire nut), and connect the red wire for the new station to the Stop terminal.

### **Adding PullCord or Single Button Control Stations:**

The EnviroDoor Operator supports N/O (Normal Open) Pullcord Switches, N/O Single Button Control Stations, and any other N/O dry contact. All N/O switches should be wired in PARALLEL and the wiring junctions can be made either at the switches (daisy-chain) or at the EnviroDoor Operator (Home-Run). Switches should be connected using two-conductor wiring (supplied) and terminated at the EnviroDoor Operator at the “Open” terminals (#5 and #6 from the bottom) as shown in the following photo (Photo 35). Color codes are not important. Do not accidentally disconnect the existing blue wire.



**Photo #35**  
("Maintained" Switches)

Switch Wiring:

Control wiring should be attached to the NEMA-4 Single Button Control Station at the lower two N/O terminals (#'s 13 & 14) as shown in the following photo (Photo 36):



**Photo #36**  
(Single Button Station Wiring)

Control wiring should be attached to the Pullcord Switch Stations at the two N/O terminals as shown in the following photo (Photo 37):



**Photo #37**  
(Pullcord Switch Station Wiring)

**NOTE:** In order to allow the Pullcord or Single Button Control Station to both **OPEN** *and* **CLOSE** the door the operator must be converted to “Sequencer Mode”. “Sequencer Mode” changes the performance of the “Open” button, allowing it to alternately issue an “Open” and then a “Close” command when actuated. To enable “Sequencer Mode”, turn the SW4 DIP switch “ON” (left). All “Open” buttons connected to the operator will now act as sequencers.

### **Installing the Miller RF Receiver:**

The Miller RF Transmitter/Receiver can be used in conjunction with NEMA-1, NEMA-4, PullCord, Single Button, and any other operator stations.

The wires from the RF Receiver are attached to the Open and 24VDC terminals in the operator. Locate the receiver in a suitable location where the wires will reach and secure it to the building or operator. Carefully route the wires from the receiver to the terminals on the operator. Use tie-wraps or other means to ensure that the wires will not get caught or pinched in the operator mechanisms.

Install the white wire on the unused terminal above the Open terminal. The yellow wire will be attached to the same terminal as the blue Open wire from the NEMA-1. The red and black wires go to the 24VDC power terminals as shown. The orange wire is not used. Your wiring should resemble the following photo (Photo 38):



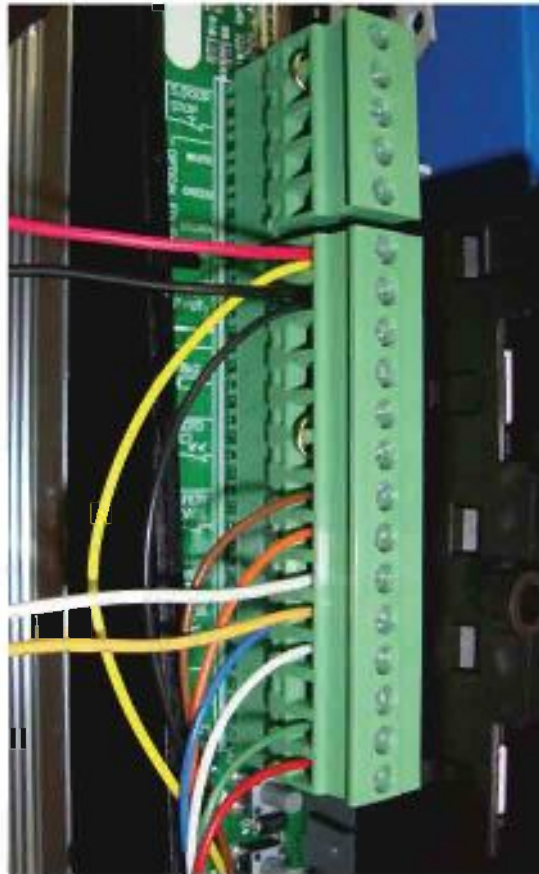

**Photo #38**  
(RF Receiver Wiring)

Per the included instructions, set the DIP switch codes on the transmitter and receiver to the same value. Your RF system should now be ready to use.

**NOTE:** In order to allow the RF Receiver to both **OPEN** *and* **CLOSE** the curtain the operator must be converted to "Sequencer Mode". "Sequencer Mode" changes the performance of the "Open" button, allowing it to alternately issue an "Open" and then a "Close" command when actuated. To enable "Sequencer Mode", turn the SW4 DIP switch "ON" (left). All "Open" buttons connected to the operator will now act as sequencers.

Door hardware, the operator, and building configurations can substantially reduce the range of your RF system. If your performance is substandard, try repositioning the green antennae wire until you get optimal performance. If good performance cannot be achieved, an external co-ax antennae can be added to your system. Please contact your local dealer or the Pioneer factory.

### **Installing the Multi-Code RF Receiver:**

The Multi-Code RF Transmitter/Receiver can be used in conjunction with NEMA-1, NEMA-4, PullCord, Single Button, and any other operator stations.

The wires from the RF Receiver are attached to the Open and 24VDC terminals in the operator. Locate the receiver in a suitable location where the wires will reach and secure it to the building or operator. Carefully route the wires from the receiver to the terminals on the operator. Use tie-

wraps or other means to ensure that the wires will not get caught or pinched in the operator mechanisms.

Install one of the gray wires on the unused terminal above the Open terminal. The other gray wire will be attached to the same terminal as the blue Open wire from the NEMA-1. The red and black wires go to the 24VDC power terminals as shown. Your wiring should resemble the following photo (Photo 39):



**Photo #39**  
(RF Receiver Wiring)

Per the included instructions, set the DIP switch codes on the transmitter and receiver to the same value. Your RF system should now be ready to use.

**NOTE:** In order to allow the RF Receiver to both **OPEN** *and* **CLOSE** the curtain the operator must be converted to "Sequencer Mode". "Sequencer Mode" changes the performance of the "Open" button, allowing it to alternately issue an "Open" and then a "Close" command when actuated. To enable "Sequencer Mode", turn the SW4 DIP switch "ON" (left). All "Open" buttons connected to the operator will now act as sequencers.

Door hardware, the operator, and building configurations can substantially reduce the range of your RF system. If your performance is substandard, try repositioning the green antennae wire until you get optimal performance. If good performance cannot be achieved, an external co-ax antennae can be added to your system. Please contact your local dealer or the Pioneer factory.